

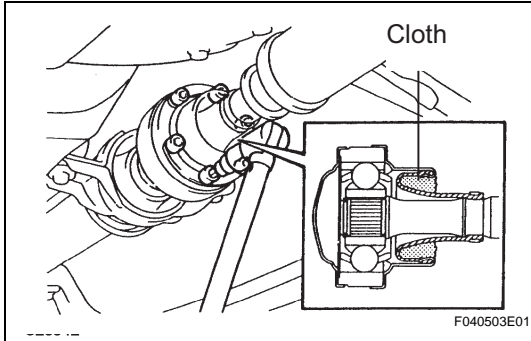

## REMOVAL

1. REMOVE ENGINE UNDER COVER ASSEMBLY
2. REMOVE ENGINE UNDER COVER NO.2
3. REMOVE PROPELLER W/CENTER BEARING SHAFT ASSEMBLY



- (a) Depress the brake pedal and hold it down.
- (b) Using a hexagon wrench (6 mm), loosen the cross groove joint set bolts a half turn.

**HINT:**

Place a cloth in the inside of the universal joint cover so that the boot does not touch the inside of the universal joint cover.

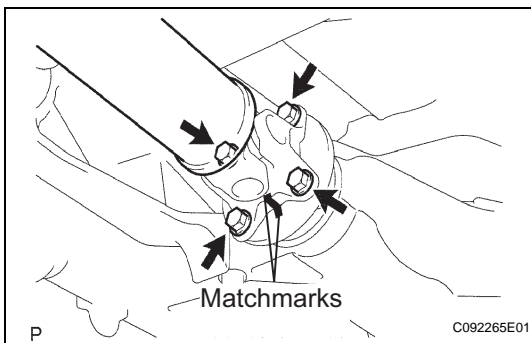

- (c) Put matchmarks on both the flanges.
- (d) Remove the 4 nuts, bolts and washers.

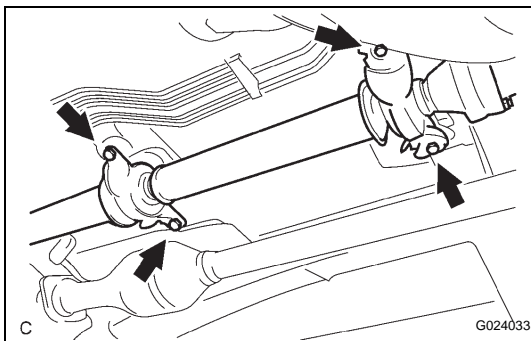

- (e) Remove the 4 bolts, 4 adjusting shims and propeller shaft w/ center bearing shaft assembly.

**NOTICE:**

- When removing the propeller shaft, do not apply excessive force to the universal joint.
- During and after the removal of the propeller shaft, keep the universal joint angle straight (within 15 degrees).
- Be careful not to damage the oil seal.

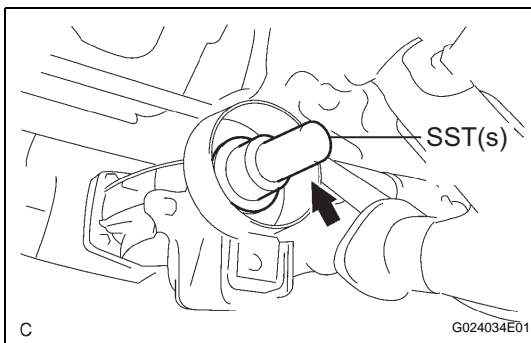

- (f) Insert SST(s) in the transfer extension housing to prevent oil leakage.

**SST 09325-20010**

**NOTICE:**

Be careful not to damage the oil seal.

## DISASSEMBLY

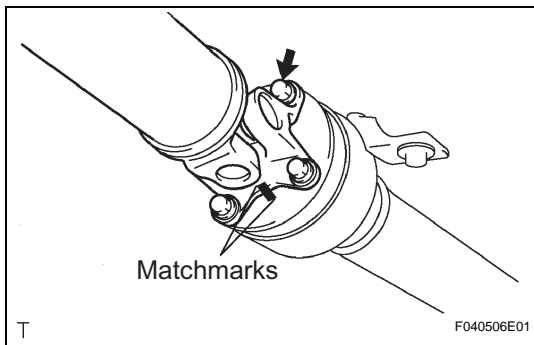

### 1. REMOVE PROPELLER SHAFT ASSEMBLY

- (a) Put matchmarks on both the flanges.
- (b) Remove the 4 nuts, bolts and washers.

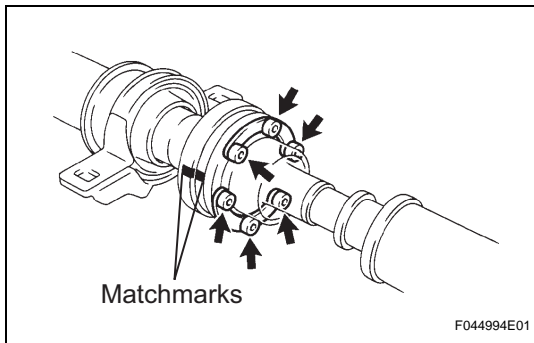

### 2. REMOVE INTERMEDIATE SHAFT

- (a) Put matchmarks on the propeller shaft sub-assembly and universal joint flange.

**NOTICE:**

**Do not use a punch for the marks.**

- (b) Using a hexagon wrench (6 mm), remove the 6 bolts and 2 washers and separate the intermediate shaft from the propeller shaft assembly rear.

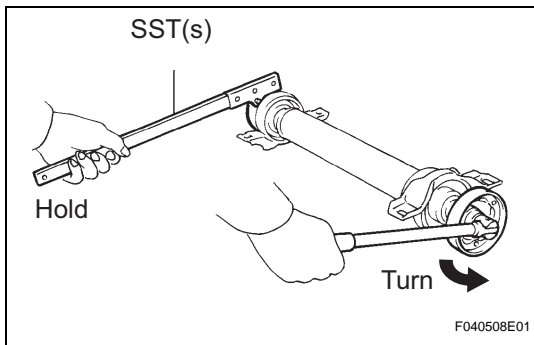

### 3. REMOVE CENTER SUPPORT BEARING ASSEMBLY NO.1

- (a) Using a chisel and a hammer, loosen the staked part of the nut.
- (b) Using SST(s) to hold the front flange, remove the nut and plate washer.

**SST 09330-00021**

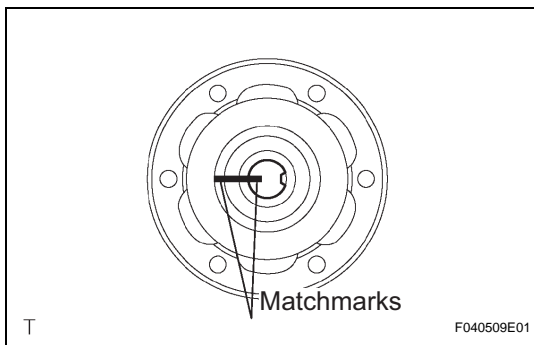

- (c) Put matchmarks on the rear flange and shaft.
- (d) Hold the intermediate shaft in a vise between aluminium plates.

**NOTICE:**

**Do not overtighten the vise.**

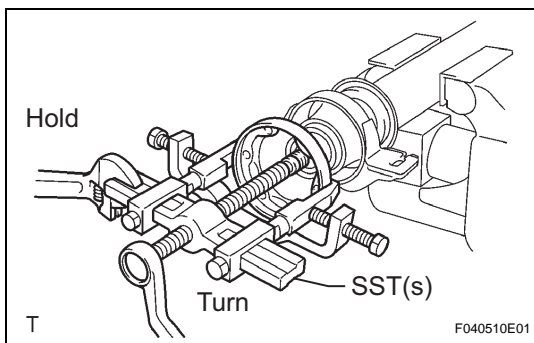

- (e) Using SST(s), remove the rear flange.

**SST 09950-40011 (09951-04020, 09952-04010, 09953-04030, 09954-04010, 09955-04061, 09957-04010, 09958-04011)**

**NOTICE:**

**Be careful not to damage the universal joint flange.**

- (f) Remove the center support bearing assembly No. 1 (rear) and washer.

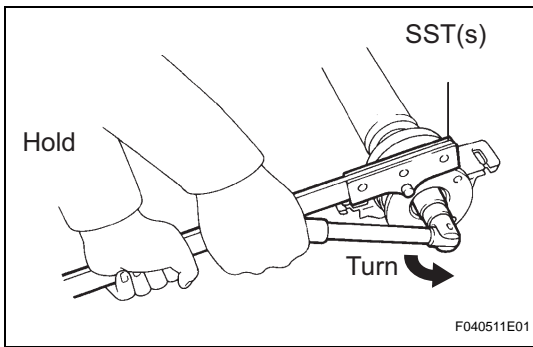

**4. REMOVE CENTER SUPPORT BEARING ASSEMBLY NO.1**

- (a) Using a chisel and a hammer, loosen the staked part of the nut.
- (b) Using SST(s) to hold the front flange, remove the nut and plate washer.

**SST 09330-00021**

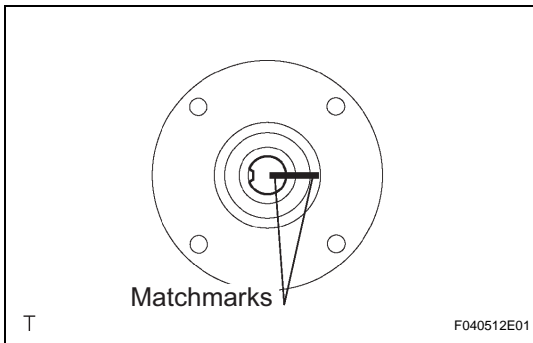

- (c) Put matchmarks on the front flange and shaft.
- (d) Hold the intermediate shaft in a vise between aluminium plates.

**NOTICE:**

**Do not overtighten the vise.**

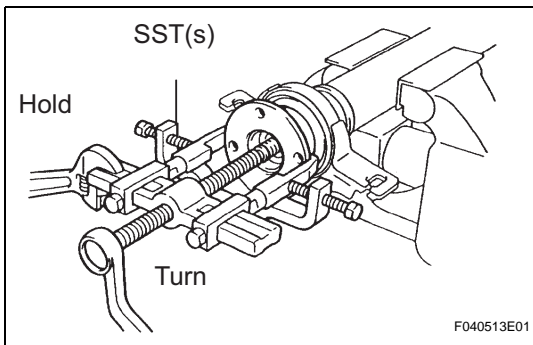

- (e) Using SST(s), remove the front flange.
- SST 09950-40011 (09951-04020, 09952-04010, 09953-04030, 09954-04010, 09955-04061, 09957-04010, 09958-04011)**

**NOTICE:**

**Be careful not to damage the universal joint flange.**

- (f) Remove the center support bearing assembly No. 1 (front) and washer.

**INSPECTION**

**1. INSPECT SPIDER BEARING**

- (a) Check that the spider bearing moves smoothly by turning the flange.
- (b) Check for the looseness around the joint by strongly moving the flange in the axial and radial directions.

**HINT:**

If necessary, replace the shaft.

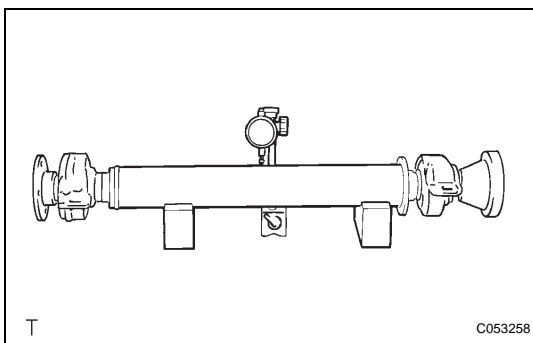
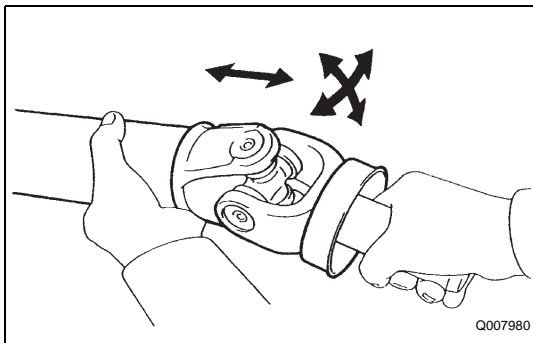

**2. INSPECT INTERMEDIATE SHAFT**

- (a) Using a dial gauge, check for the swing of the intermediate shaft.

**Maximum swing:**

**0.8 mm (0.031 in.)**

**NOTICE:**

**The dial gauge must be set at right angles to the center of the intermediate shaft.**

**HINT:**

If shaft swing exceeds the maximum, replace the shaft.

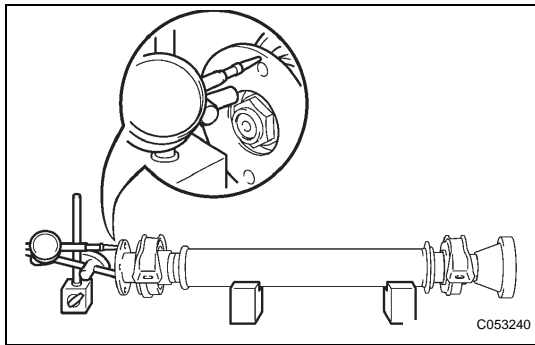

- (b) Using a dial gauge, check for the runout of the front side of the intermediate shaft flange.

**Maximum runout:**

**0.1 mm (0.004 in.)**

**NOTICE:**

**Ensure that the dial gauge is set at right angles to the measurement surface.**

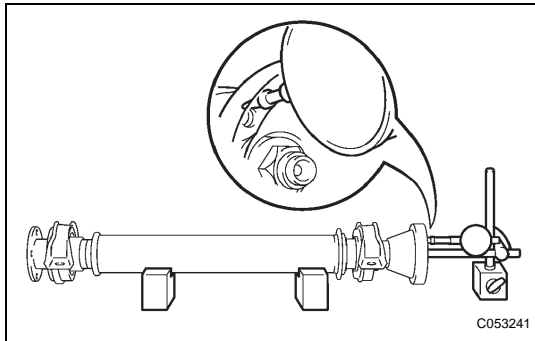

- (c) Set a dial gauge outside the bolt hole on the rear side flange of the intermediate shaft, and check for runout in the horizontal direction.

**Maximum runout:**

**0.1 mm (0.004 in.)**

**NOTICE:**

**Ensure that the dial gauge is set at right angles to the measurement surface.**

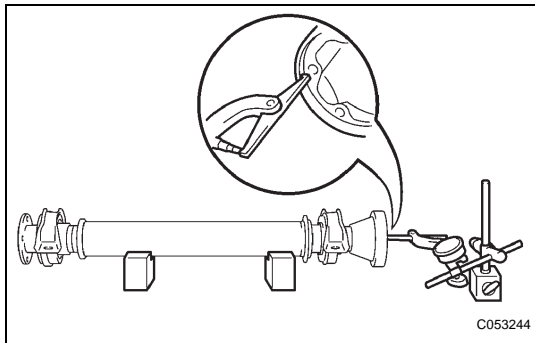

- (d) Set a dial gauge to the circumference of the intermediate shaft flange, and check for runout in the vertical direction.

**Maximum runout:**

**0.1 mm (0.004 in.)**

**NOTICE:**

**Ensure that the dial gauge is set at right angles to the measurement surface.**

**HINT:**

If the intermediate shaft flange runout exceeds the maximum, replace the intermediate shaft.

### 3. INSPECT PROPELLER SHAFT ASSEMBLY

- (a) Using a dial gauge, check for the swing of the propeller shaft assembly.

**Maximum swing:**

**0.8 mm (0.031 in.)**

**HINT:**

If shaft swing exceeds the maximum, replace the propeller shaft assembly.

**NOTICE:**

**The dial gauge must be set at right angles to the center of the propeller shaft.**

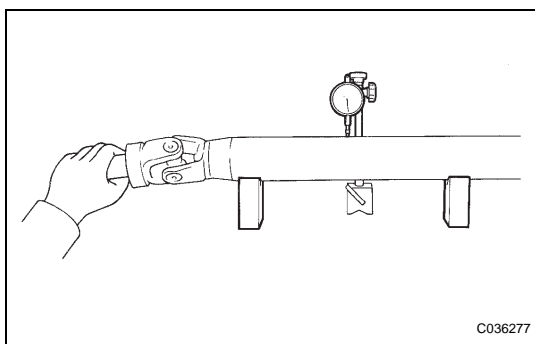

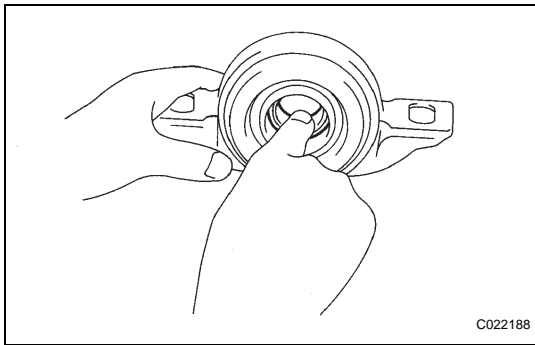

C022188

**4. INSPECT CENTER SUPPORT BEARING ASSEMBLY NO.1**

- (a) Turn the bearing by hand with applying force in the direction of rotating. Check that the bearing turns smoothly.
- (b) Check that the seals and bracket are not cracked or damaged.

**HINT:**

If the bearing is damaged, worn, or does not turn smoothly, replace it.

**5. INSPECT CENTER SUPPORT BEARING ASSEMBLY NO.1**

- (a) Inspect the center support bearing assembly No. 1 (rear) following the same procedures as for the center support bearing assembly No. 1 (front).

**6. INSPECT PROPELLER SHAFT ASSEMBLY REAR**

- (a) Using a dial gauge, check for the runout of the rear propeller shaft assembly rear.

**Maximum runout:**

**0.8 mm (0.031 in.)**

**HINT:**

If the shaft runout exceeds the maximum, replace the rear propeller shaft assembly rear.

**NOTICE:**

**The dial gauge must be set at right angles to the center of the propeller shaft.**

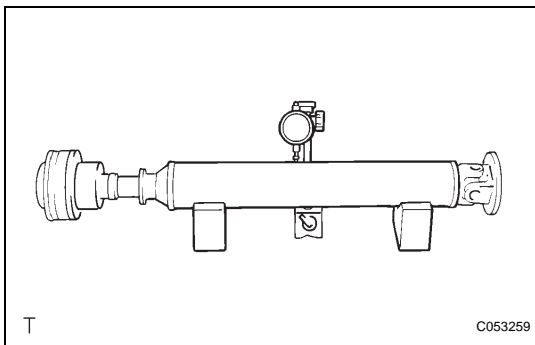

T

C053259

**REASSEMBLY**

**1. INSTALL CENTER SUPPORT BEARING ASSEMBLY NO.1**

- (a) Set the center support bearing assembly No. 1 (front) to the intermediate shaft, as shown in the illustration.
- (b) Install a new washer to the intermediate shaft.

**NOTICE:**

**Be sure to install the bearing in the correct direction.**

- (c) Align the matchmarks on the front flange and shaft, and place the flange on the shaft.

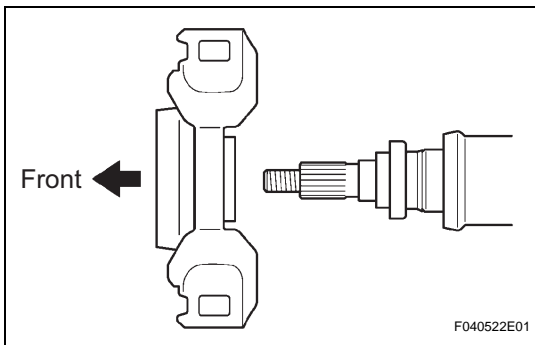

F040522E01

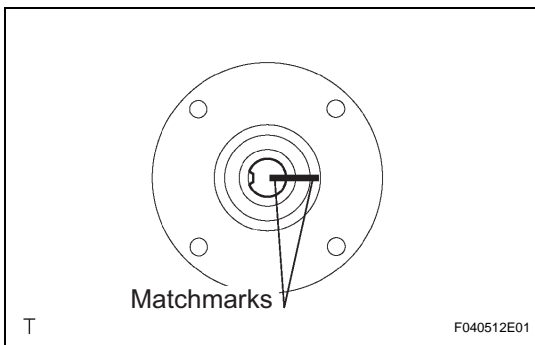

T

F040512E01

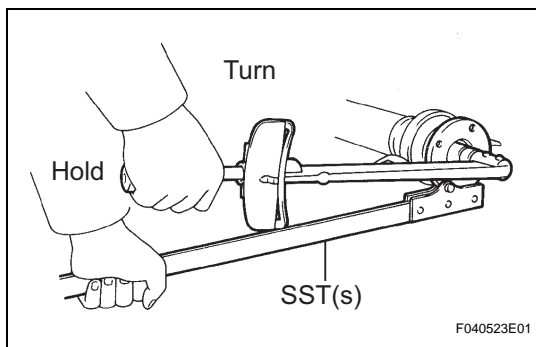

- (d) Using SST(s) to hold the front flange, press the center support bearing assembly No. 1 (front) into the position by tightening down with a new nut and plate washer.

**SST 09330-00021**

**Torque: 182 N\*m (1,850 kgf\*cm, 134 ft.\*lbf)**

- (e) Loosen the nut.  
(f) Torque the nut again.

**Torque: 69 N\*m (700 kgf\*cm, 51 ft.\*lbf)**

- (g) Using a chisel and a hammer, stake the nut.

## 2. INSTALL CENTER SUPPORT BEARING ASSEMBLY NO.1

- (a) Set the center support bearing assembly No. 1 (rear) on the shaft, as shown in the illustration.

- (b) Install a new washer to the shaft.

**NOTICE:**

**Be sure to install the bearing in the correct direction.**

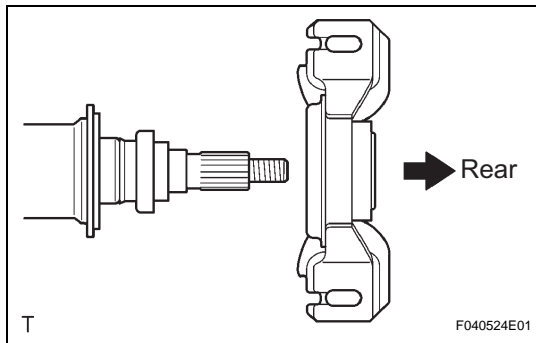

- (c) Align the matchmarks on the rear flange and shaft, and place the flange on the shaft.

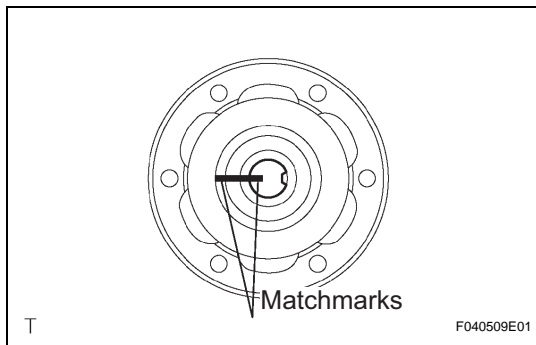

- (d) Using SST(s) to hold the front flange, press the center support bearing assembly No. 1 (rear) into the position by tightening down with a new nut and plate washer.

**SST 09330-00021**

**Torque: 182 N\*m (1,850 kgf\*cm, 134 ft.\*lbf)**

- (e) Loosen the nut.  
(f) Torque the nut again.

**Torque: 69 N\*m (700 kgf\*cm, 51 ft.\*lbf)**

- (g) Using a chisel and a hammer, stake the nut.

## 3. INSTALL INTERMEDIATE SHAFT

- (a) Align the matchmarks on the intermediate shaft and rear propeller shaft assembly rear, then install the 2 washers and 6 bolts.

- (b) Using a hexagon wrench (6 mm), loosely tighten the 6 bolts.

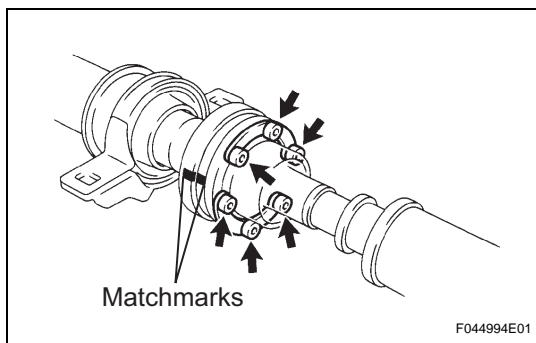
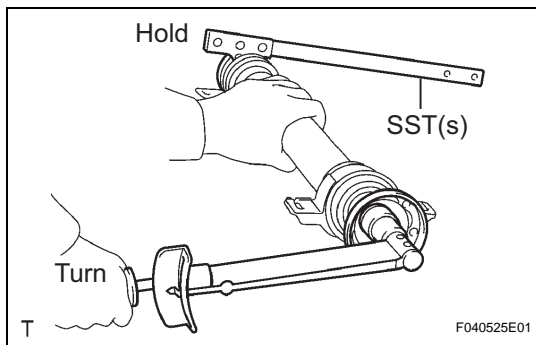



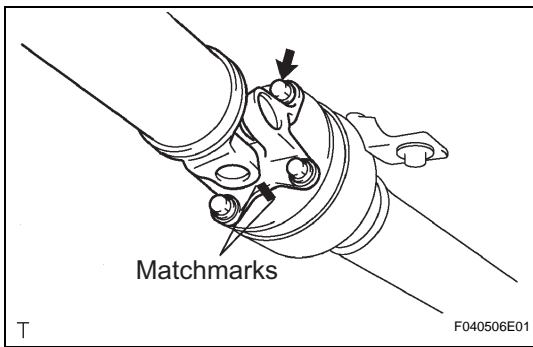

**4. INSTALL PROPELLER SHAFT ASSEMBLY**

- (a) Align the matchmarks on the propeller shaft assembly flange and front flange, and connect the shaft with the 4 bolts, washers and nuts.  
**Torque: 74 N\*m (750 kgf\*cm, 54 ft.\*lbf)**
- (b) Check that each joint of the propeller shaft is facing in the correct direction, as shown in the illustration below.

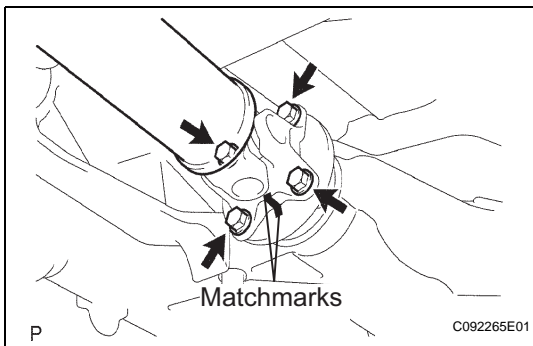
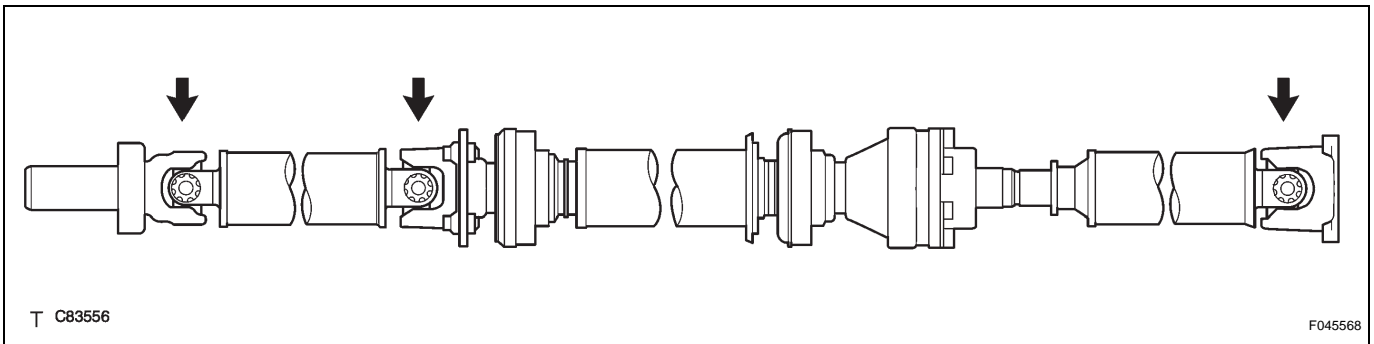

**INSTALLATION**

**1. INSTALL PROPELLER W/CENTER BEARING SHAFT ASSEMBLY**

- (a) Align the matchmarks on the propeller shaft assembly rear flange and differential companion flange, and connect the shaft with the 4 bolts, washers and nuts.

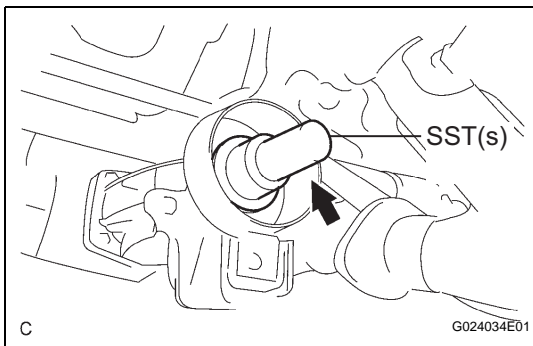

- (b) Remove SST(s) from the extension housing.
- (c) Insert the yoke into the extension housing.

**NOTICE:**

- Be careful not to damage the oil seal.
- Be careful not to damage the universal joint boot when installing the propeller shaft.

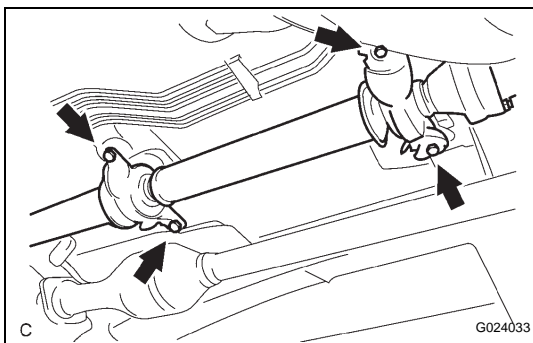

- (d) Install the 4 adjusting shims and propeller shaft w/ center bearing, and loosely tighten the 4 bolts.



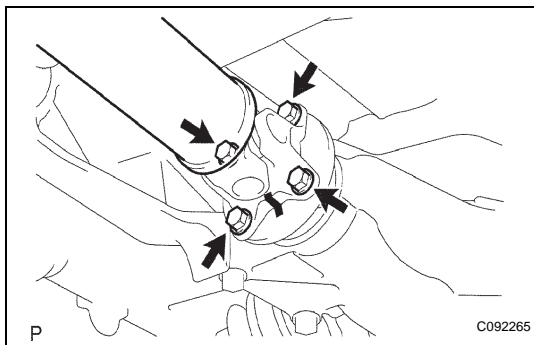

- (e) Tighten the 4 nuts.  
**Torque: 74 N\*m (750 kgf\*cm, 54 ft.\*lbf)**

## 2. FULLY TIGHTEN PROPELLER W/CENTER BEARING SHAFT ASSEMBLY

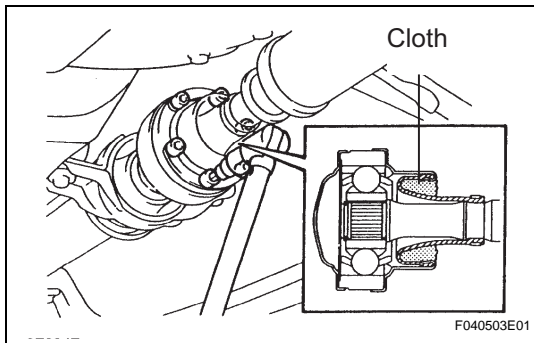

- (a) Remove the cloth from the joint.  
 (b) Using a hexagon wrench (6 mm), tighten the 6 bolts.  
**Torque: 29 N\*m (296 kgf\*cm, 21 ft.\*lbf)**

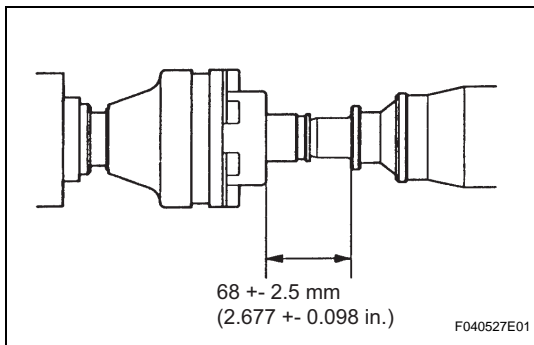

- (c) With the vehicle unloaded, adjust the dimension between the rear side of the cover and shaft, as shown in the illustration.

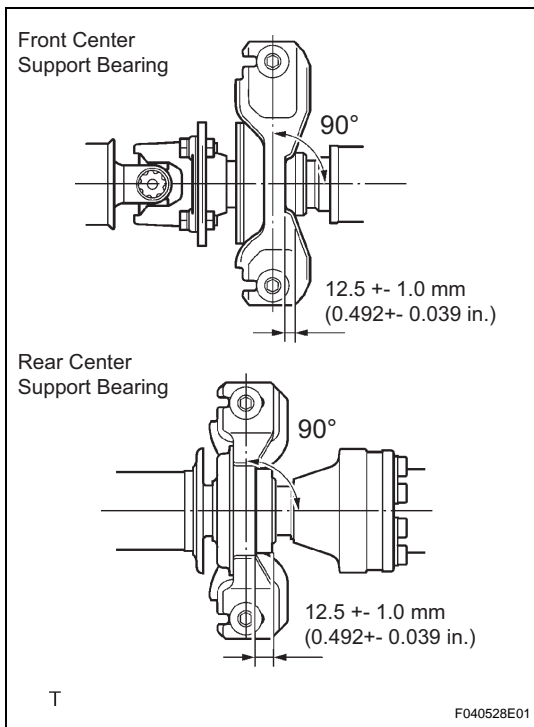

- (d) Adjust the front and rear dimensions between the edge surface of the center support bearing and the edge surface of the cushion to 12.5 +/- 1.0 mm (0.492 +/- 0.039 in.) respectively as shown in the illustration, then torque the bolts.  
**Torque: 37 N\*m (375 kgf\*cm, 27 ft.\*lbf)**
- (e) Check that the center line of the bracket is at right angles to the shaft axial direction.
- (f) If any vibration or noise occurs, perform joint angle check as follows and replace the adjusting shim with a proper one.
- (1) Turn the propeller shaft several times by hand to stabilize the center support bearings.
  - (2) Using a jack, raise and lower the differential to stabilize the differential mounting cushion.
  - (3) Remove the transfer dynamic damper.
  - (4) Using SST(s), measure the installation angle of the transfer extension housing (A) and front propeller shaft (B).  
**SST 09370-50010**  
**No. 1 joint angle:**  
**A minus B = 0°18' to 2°18'**

- (5) Using SST(s), measure the installation angle of the rear propeller shaft (C) and rear differential (D).

**SST 09370-50010**

**No. 2 joint angle:**

**C minus D = -0°41' to -2°41'**

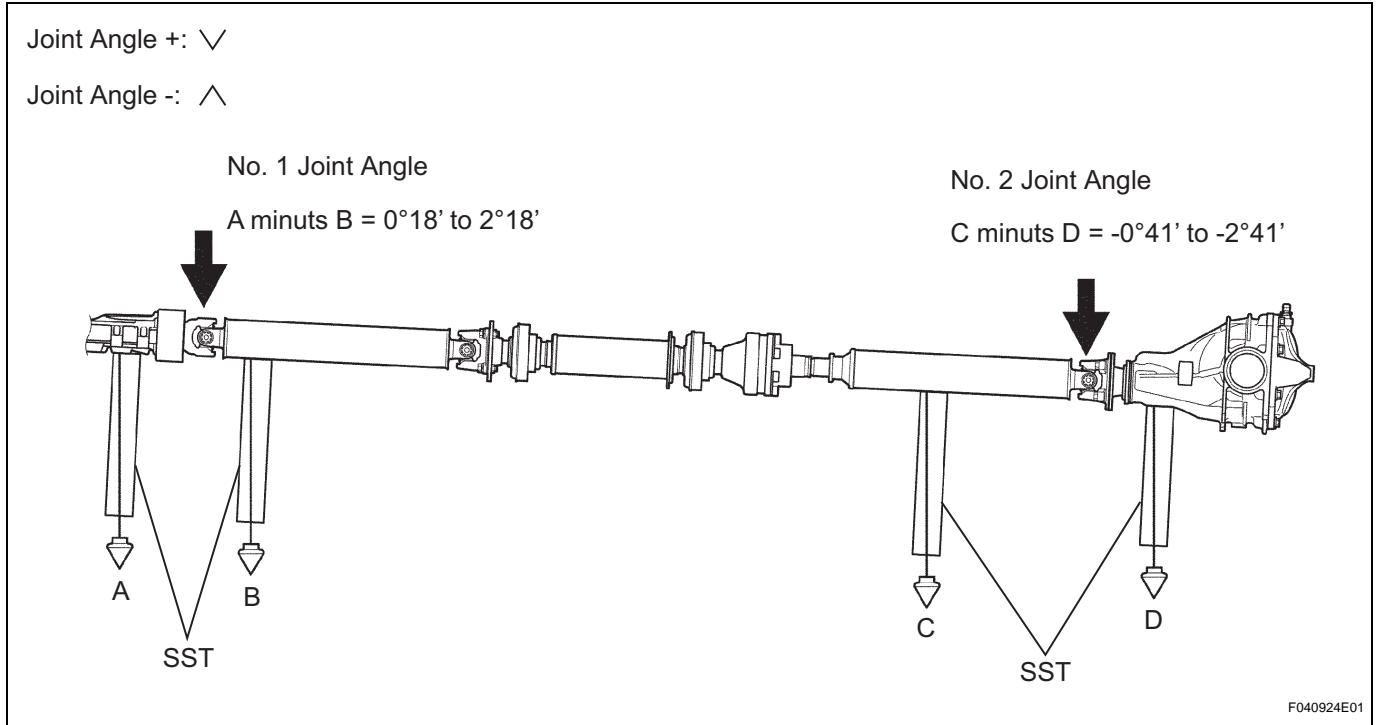

If the measured angle is not within the specification, adjust with the center support bearing adjusting shim.

**Center support bearing adjusting shim thickness**

Thickness mm (in.)	Thickness mm (in.)
3.2 (0.126)	4.5 (0.177)
6.5 (0.256)	9.0 (0.354)
11.0 (0.433)	13.5 (0.531)
15.5 (0.610)	17.5 (0.689)

**PR**

- (g) Install the transfer dynamic damper.

**Torque: 26 N\*m (260 kgf\*cm, 19 ft.\*lbf)**

3. **INSTALL ENGINE UNDER COVER NO.2**
4. **INSTALL ENGINE UNDER COVER ASSEMBLY**